

PROGRESS CLAUSE

RC/City of Owosso

1 OF 1

Dec, 2018

The Contractor shall submit at the pre-construction meeting a complete Progress Schedule to the City Engineer. The Progress Schedule shall include, as a minimum, the controlling work items for the completion of the project and the planned dates that these work items will be the controlling operations: all for each of the four project work sites. All Contract dates including open to traffic, project completion, holidays, and other controlling dates of the Contract must be included in the progress schedule. All specific work requirements of the 'Maintaining Traffic' Special Provision that affect the Progress Schedule shall be incorporated within the Progress Schedule.

Do not start work on roadway or utilities until the date approved by the Engineer, which date must be no earlier than July 8, 2019.

The project must be completely open to traffic on or before August 30, 2019.

Failure to complete all work within these dates will result in the Contractor being assessed liquidated damages in accordance with subsection 108.10.C.1 of the MDOT 2012 Standard Specifications for Construction.

Unless specific pay items are provided in the Contract, any extra costs incurred by the Contractor due to cold-weather protection, winter grading, sufficient manpower and equipment necessary to maintain the schedule, and/or meet final completion date, and any overtime; will not be paid for separately, but will be included in payment of other contract items.

After award and prior to the start work date, the Contractor must attend a preconstruction meeting with the Engineer. The Engineer will determine the day, time and place for the preconstruction meeting. The Contractor is encouraged to contact any of its sub-contractors to attend the preconstruction meeting. The Contractor and its sub-contractors shall submit a Progress Schedule at the preconstruction meeting and be ready to discuss same at the meeting.

Failure on the Contractor's part to carry out the provisions of this Project Clause may be considered sufficient cause to prevent Contractor from bidding future projects.

**SPECIAL PROVISION
FOR
TECHNICAL SPECIFICATIONS**

RC/City of Owosso

1 OF 1

Dec, 2018

General Requirement

The MDOT 2012 STANDARD SPECIFICATIONS FOR CONSTRUCTION shall govern all technical specifications for this project. The following parts of the Contract will prevail over all other parts in the following order:

1. Special Provisions.
2. Supplemental Specifications.
3. Project Plans and Drawings.
4. MDOT Standard Plans.
5. 2012 Standard Specifications
6. City of Owosso Standard Specifications.

The Contractor shall not take advantage of any apparent error or omission in the contract documents. If any uncertainty, inconsistency, omission, or conflict is discovered within the contract documents, the Engineer will solely decide as to the true intent of the language.

NOTICE TO BIDDERS

UTILITY COORDINATION

City of Owosso/RC

1 of 2

Dec, 2018

The Contractor shall cooperate and coordinate construction activities with the owners of utilities as stated in Section 104.08 of the Michigan Department of Transportation 2012 Standard Specifications for Construction. In addition, for the protection of underground utilities, the contractor shall follow the requirements in Section 107.12 of the Michigan Department of Transportation 2012 Standard Specifications for Construction. Contractor delay claims, resulting from a utility, will be determined based upon Section 108.09 of the Michigan Department of Transportation 2012 Standard Specifications for Construction.

For protection of underground utilities and in conformance with Public Act 53, the Contractor shall dial 1-800-482-7171 (or 811) a minimum of three full working days, excluding Saturdays, Sundays, and holidays prior to beginning each excavation in areas where public utilities have not been previously located. Members will thus be routinely notified. This does not relieve the Contractor of the responsibility of notifying utility owners who may not be a part of the "Miss Dig" alert system.

The following Public Utilities have facilities located in the road right-of-way or project area:

<u>NAME AND ADDRESS OF OWNER</u>	<u>KIND OF UTILITY</u>	<u>PHONE NUMBER</u>
Charter Communication 1480 S. Valley Center Dr Bay City, Michigan 48706	Cable Television	(989) 233-9404 Mark Kelly mark.kelly@charter.com
Frontier 1943 W. M-21 Owosso, Michigan 48867	Fiber	(989) 723-0373 Mark Stevens mark.stevens@ftr.com
Consumers Energy 530 West Willow Street PO Box 30162 Lansing, Michigan 48909	Gas	(517) 614-8570 Adam Bertram adam.bertram@cmsenergy.com
Consumers Energy 530 West Willow Street PO Box 30162 Lansing, Michigan 48906	Electric	(989) 729-3250 Tracy Mahar tracy.mahar@cmsenergy.com
City of Owosso 301 W. Main Street Owosso, Michigan 48867	Water	(989) 725-0555 Glenn Chinavare glenn.chinavare@ci.owosso.mi.us

City of Owosso
301 W. Main Street
Owosso, Michigan 48867

Sanitary Sewer

(989) 725-0555
Glenn Chinavare
glenn.chinavare@ci.owosso.mi.us

Daystarr Communications
307 N. Ball Street
Owosso, MI 48867

Fiber

(989) 720-6023
Brent Klein
brent.klein@daystarrfiber.net

City Engineer
301 W. Main Street
Owosso, Michigan 48867

Road and Storm Drainage

(989) 725-0550
Randy Chesney, P.E.
randy.chesney@ci.owosso.mi.us

Soil Erosion and Sedimentation Control
Shiawassee County Health Department
Environmental Health Division
201 N. Shiwassee Street
Corunna, MI 48817

Soil Erosion and
Sedimentation Control

(989) 743-2289
Steve Alworden
salworden@shiwaseechd.net

The owners of existing service facilities that are within grading or structure limits and in conflict will move them to locations designated by the Construction Engineer or will remove them entirely from the highway Right-of-Way. Owners of Public Utilities will not be required by the City of Owosso to move additional poles or structures in order to facilitate the operation of construction equipment unless it is determined by the Construction Engineer that such poles or structures constitute a hazard to the public or are extraordinarily dangerous to the contractor's operations.

The existing utilities shown on the plans represent the best information available as obtained from survey and existing records. This information does not relieve the Contractor of the responsibility of protecting all existing utilities, in case utilities have been constructed or removed since the survey date or if utilities are encountered in different locations or if any utilities are not shown on the plans.

All existing utilities shall be located as to both horizontal and vertical position prior to starting any utility construction or other excavation. Cost shall be included in the new utility or excavation pay item.

The Contractor's attention is directed to the requirements for cooperation with others, as covered in Section 104.08 of the MDOT 2012 Standard Specification for Construction.

UTILITY DAMAGE

The Contractor shall be responsible for the protection of all existing utilities during construction of this project. Any utilities damaged by the Contractor shall be repaired in accordance with the related utilities specifications at the Contractor's expense.

UTILITY REPLACEMENTS

There are no utility replacements for the project.

CITY OF OWOSSO
SPECIAL PROVISION
FOR
MAINTAINING TRAFFIC

City of Owosso/RC

1 of 3

Dec, 2018

a. Description. The project will consist of 0.85 mile of road crushing, shaping, base stabilizing, HMA cold-milling, and HMA resurfacing on four city streets: Allendale Avenue, Abrey Avenue, Monroe Street, and North Street, all in the City of Owosso, Shiawassee County.

b. General. Traffic shall be maintained in accordance with Sections 104.07C, 104.11, 812, and 922 of the Michigan Department of Transportation (MDOT) 2012 Standard Specifications for Construction, including any typical drawings or supplemental specifications and as specified herein.

The Contractor shall coordinate their operations with other Contractors, City of Owosso and its residents, and private utilities who are within the CIA to eliminate conflicts in traffic control. No additional payment will be made to the Contractor for the joint use of traffic control items.

The Contractor shall notify the Engineer, City of Owosso (989-725-0550), Shiawassee County Central Dispatch (989-743-9111), Local Fire Department(s) (989-725-0580), Owosso Middle School (989-723-3460), and School Operations Director (989-413-5246) that service the area a minimum of three full working days prior to the implementation of any detours or road closures.

c. Construction Influence Area (CIA). The Construction Influence Area (CIA) shall include right-of-ways of the four streets under construction and extend a distance of 0.5 miles beyond the endpoints and include the right-of-way of all intersecting streets within the project limits for a distance of 300 feet laterally from the construction centerlines of the four streets under construction.

The CIA shall also include the rights-of-way of any designated detour routes within the limits of the construction and detour signing.

d. Traffic Restrictions. The roads shall be closed to through traffic. Residents shall be allowed to access their driveways at all times, except when construction requires short term closures. Monroe Street traffic will be detoured as shown in the construction plans. North Street traffic shall be detoured as shown in the construction plans.

Reasonable access to intersecting roads/streets and residential/commercial drives shall be maintained at all times. The Contractor may temporarily close alternate drives if a business or residence has multiple drives on the same roadway, except for drives that operate directionally (i.e., one-way drives).

Should traffic regulators be assigned to maintain local traffic through the construction area, the cost for traffic regulators will not be paid for separately but will be considered as part of the pay item Minor Traffic Devices.

The Contractor shall work between the hours of 7:00 a.m. and 7:00 p.m., Monday through Saturday. No work is allowed outside these time periods. The Contractor must provide a 24-hour notice for Saturday work. The Contractor shall coordinate work so that any necessary preliminary or closing operations are also done within these time periods.

No work shall be allowed during the Memorial Day or Labor Day weekends or the Fourth of July.

The Contractor shall place maintenance gravel the same workday that the pavement is removed in all locations of the project to maintain access to adjacent properties. Any damage occurring to the subgrade from exposure to the elements will be undercut and replaced in accordance with Subgrade Undercutting, Type II, at the Contractor's expense.

The Contractor shall place aggregate base the same workday that earth is excavated in all locations of the project. Any damage occurring to the subgrade from unnecessary exposure to the elements will be undercut and replaced in accordance with Subgrade Undercutting, Type II, at the Contractor's expense.

Rubbish collection is done by private contractors between the hours of 7:00 a.m. and 7:00 p.m. according to the following schedule: All residential customers north of Main Street are serviced on Thursdays. All residential customers south of Main Street are serviced on Tuesdays. Rubbish collected at commercial properties is collected any time/date. The Contractor shall schedule work to allow and provide for rubbish collectors to provide their service to the residential and commercial properties. If the rubbish collectors are unable to collect materials due to construction operations, then the Contractor shall coordinate with the rubbish collectors the moving of containers to the collection site and returning same containers to the property owner.

Current mail delivery is to doorstep of each residence. Mail delivery person will park vehicle on side-street and walk to residence to make delivery. Contractor shall conduct work so that the mail person may walk unimpeded around construction work to make mail delivery.

e. Traffic Control Devices. All signs, barricades, warning lights, and other traffic control devices shall be in accordance with the 2011 Edition of the Michigan Manual of Uniform Traffic Control Devices (MMUTCD).

All diamond shaped warning signs shall be 48" x 48." All temporary signs shall be mounted at a minimum seven-foot bottom height. All temporary signs used for detour, except those at Type III Barricades, shall be installed on driven posts.

Temporary signs which are to remain in place for fourteen (14) days or more shall be installed on driven posts as directed by the Engineer. All other temporary signs (excluding detour signs) may be installed on portable supports.

Ground driven sign supports for temporary signs shall be installed in accordance with MDOT Special Detail WZD-100-A.

Advance work zone signing is revised to include R5-18c (Work Zone Begins) signs. Install signs at locations shown in the plans or as directed by the engineer.

For construction signing, layout as shown on MDOT typicals minimum Merging Taper Lengths "L," distances between Traffic Control Devices "D," and length of Longitudinal Buffer Length "B" shall be in accordance with Typical Sign Sequence M0020a.

W20-1 "Road Work Ahead" signs shall be placed on all intersecting roads at a minimum distance shown on the plans, or as directed by the Engineer.

Signs placed at Type III barricades shall be placed above and behind the barricade on their own supports.

f. Permanent Pavement Markings. Permanent pavement markings shall consist of:

Pavt Mrkg, Ovly Cold Plastic, Railroad Sym
Pavt Mrkg, Ovly Cold Plastic, 24 inch, Stop Bar

Final pavement markings shall be installed within 3 days of placement of the top course (weather permitting).

The contractor shall place permanent pavement markings in accordance with Section 811 of the MDOT 2012 Standard Specifications for Construction, the Pavement Marking Plans, and the most current version of the MDOT Pavement Marking Typical Plans PAVE-900-Series.

g. Measurement and Payment. The Maintaining Traffic Pay Items will be paid for at the Contract Unit Price in accordance with the MDOT 2012 Standard Specifications for Construction, with exception by other Special Provisions, which shall be payment in full for all labor, material, and equipment needed to accomplish this work.

Payment for temporary signs will be made based on the maximum square feet of dissimilar sign legends in use at any one time during the project.

Payment for barricades, lighted arrows, and plastic drums will be made based on the maximum number in use at any one time during the project.

SIGN MATERIAL SELECTION TABLE

SIGN SIZE	SIGN MATERIAL TYPE		
	TYPE I	TYPE II	TYPE III
≤ 36" X 36"		X	X
>36" X 36" < 96" TO WIDE		X	
> 96" WIDE TO 144" WIDE	X	X	
> 144" WIDE	X		

TYPE I ALUMINUM EXTRUSION
 TYPE II PLYWOOD
 TYPE III ALUMINUM SHEET

ROUNDING OF CORNERS IS NOT REQUIRED FOR TYPE I OR II SIGNS.
 VERTICAL JOINTS ARE NOT PERMITTED.
 HORIZONTAL JOINTS THROUGH SIGN LEGEND OR SYMBOLS ARE NOT PERMITTED.

POST SIZE REQUIREMENTS TABLE

SIGN AREA (ft ²)	POST TYPE		
	U-CHANNEL STEEL	SQUARE TUBULAR STEEL	WOOD
≤9	1 - 3 lb/ft*	1 - 2" 12 or 14 GA*	N/A
9 ≤ 20	2 - 3 lb/ft	2 - 2" 12 or 14 GA	1 - 4" X 6"*
> 20 ≤ 30	N/A	N/A	2 - 4" X 6"
> 30 ≤ 60	N/A	N/A	2 - 6" X 8"
> 60 ≤ 84	N/A	N/A	3 - 6" X 8"

*SIGNS 4 FEET AND GREATER IN WIDTH REQUIRE 2 POSTS.
 SIGNS GREATER THAN 8 FEET IN WIDTH REQUIRE 2 OR 3 WOOD
 POSTS DEPENDING ON AREA OF SIGN.
 A MAXIMUM OF 2 POSTS WITHIN A 7' PATH IS PERMITTED.

 PREPARED BY OPERATIONS FIELD SERVICES	DEPARTMENT DIRECTOR Kirk T. Steudle APPROVED BY: _____ DIRECTOR, BUREAU OF FIELD SERVICES	MICHIGAN DEPARTMENT OF TRANSPORTATION BUREAU OF FIELD SERVICES SPECIAL DETAIL FOR GROUND DRIVEN SIGN SUPPORTS FOR TEMP SIGNS		
	DRAWN BY: <u>CON/ECH</u> CHECKED BY: <u>AUG</u>	APPROVED BY: _____ DIRECTOR, BUREAU OF HIGHWAY DEVELOPMENT	F.H.W.A. APPROVAL _____	<u>7/20/2016</u> PLAN DATE

2 POST SIGN SUPPORT SPACING

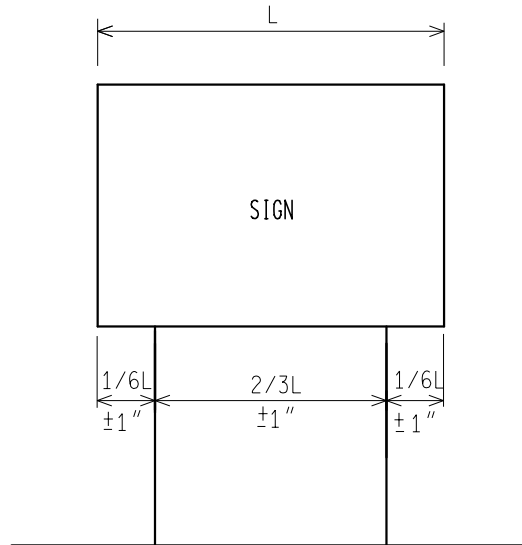

3 POST SIGN SUPPORT SPACING

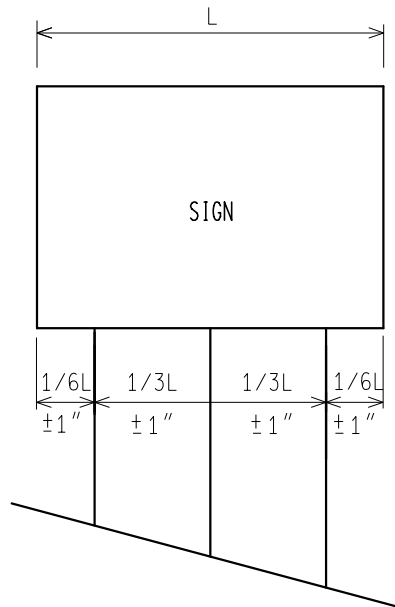

* FOR ALL 11' AND 12' LONG SIGNS ON 3 WOOD SUPPORTS, SPREAD POSTS SO AS TO HAVE A 8' MIN. TO 9' MAX. DISTANCE BETWEEN OUTSIDE POSTS.

NOT TO SCALE

MICHIGAN DEPARTMENT OF TRANSPORTATION
BUREAU OF FIELD SERVICES SPECIAL DETAIL

F.H.W.A. APPROVAL

7/20/2016
PLAN DATE

WZD-100-A

SHEET
2 OF 11

NOTE: THE ORIGINAL SIGNED COPY IS KEPT ON FILE AT THE MICHIGAN DEPARTMENT OF TRANSPORTATION.

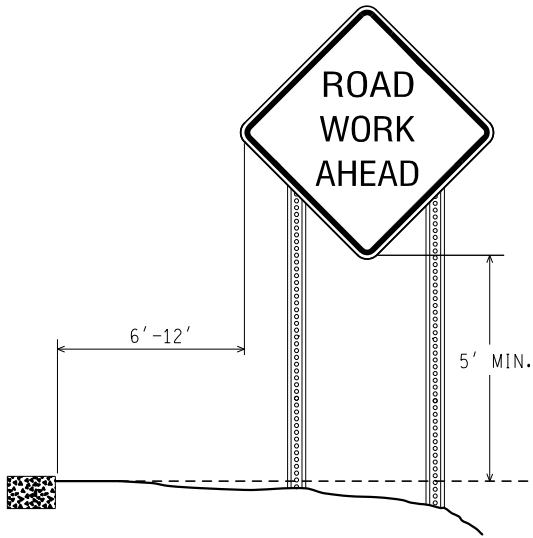

RURAL

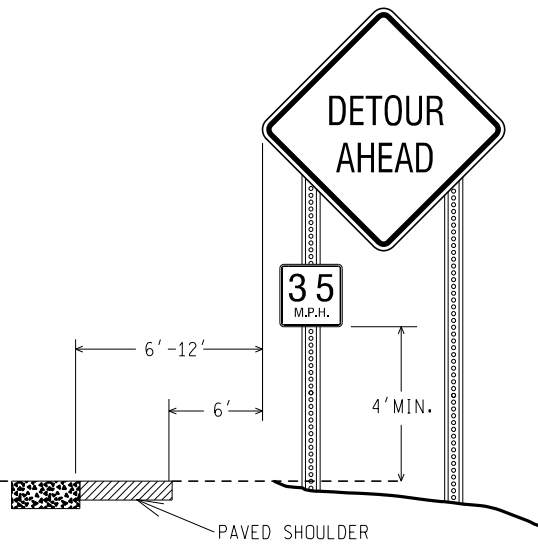

RURAL WITH ADVISORY SPEED PLATE

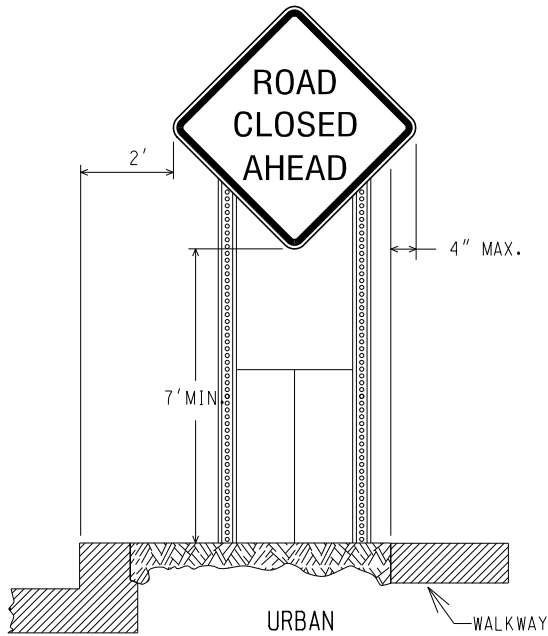

URBAN

(CURBED AREAS OR WHERE WALKWAYS ARE PRESENT)

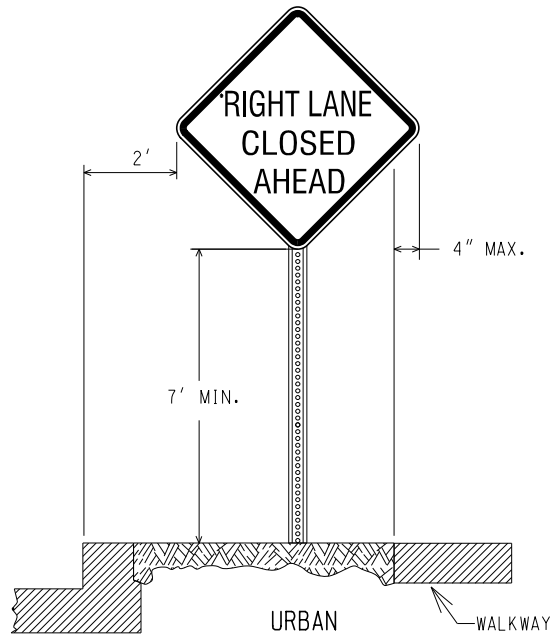

URBAN

(CURBED AREAS OR WHERE WALKWAYS ARE PRESENT)

BOTTOM HEIGHT AND OFFSET

NOT TO SCALE

MICHIGAN DEPARTMENT OF TRANSPORTATION
BUREAU OF FIELD SERVICES SPECIAL DETAIL

F.H.W.A. APPROVAL

7/20/2016
PLAN DATE

WZD-100-A

SHEET
3 OF 11

NOTE: THE ORIGINAL SIGNED COPY IS KEPT ON FILE AT THE MICHIGAN DEPARTMENT OF TRANSPORTATION.

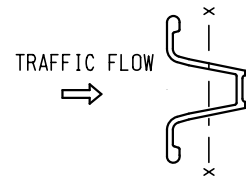
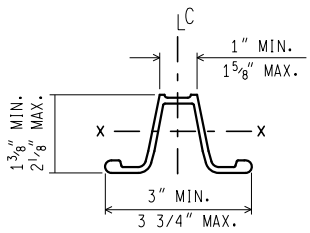
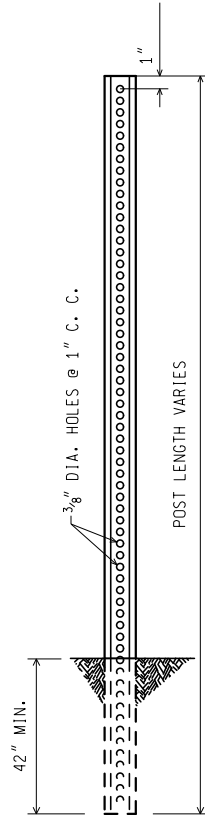

WEIGHT = 3 lbs/ft
 SECT. MOD. X.-X. = 0.31 CUBIC INCHES MIN.

3 lb. U - CHANNEL STEEL POST
 (NO SPLICE)

MOUNT SIGN ON OPEN FACE OF
 U - CHANNEL STEEL POST

NOT TO SCALE

MICHIGAN DEPARTMENT OF TRANSPORTATION BUREAU OF FIELD SERVICES SPECIAL DETAIL	F.H.W.A. APPROVAL	7/20/2016 PLAN DATE	WZD-100-A	SHEET 4 OF 11
--	-------------------	------------------------	-----------	------------------

NOTE: THE ORIGINAL SIGNED COPY IS KEPT ON FILE AT THE MICHIGAN DEPARTMENT OF TRANSPORTATION.

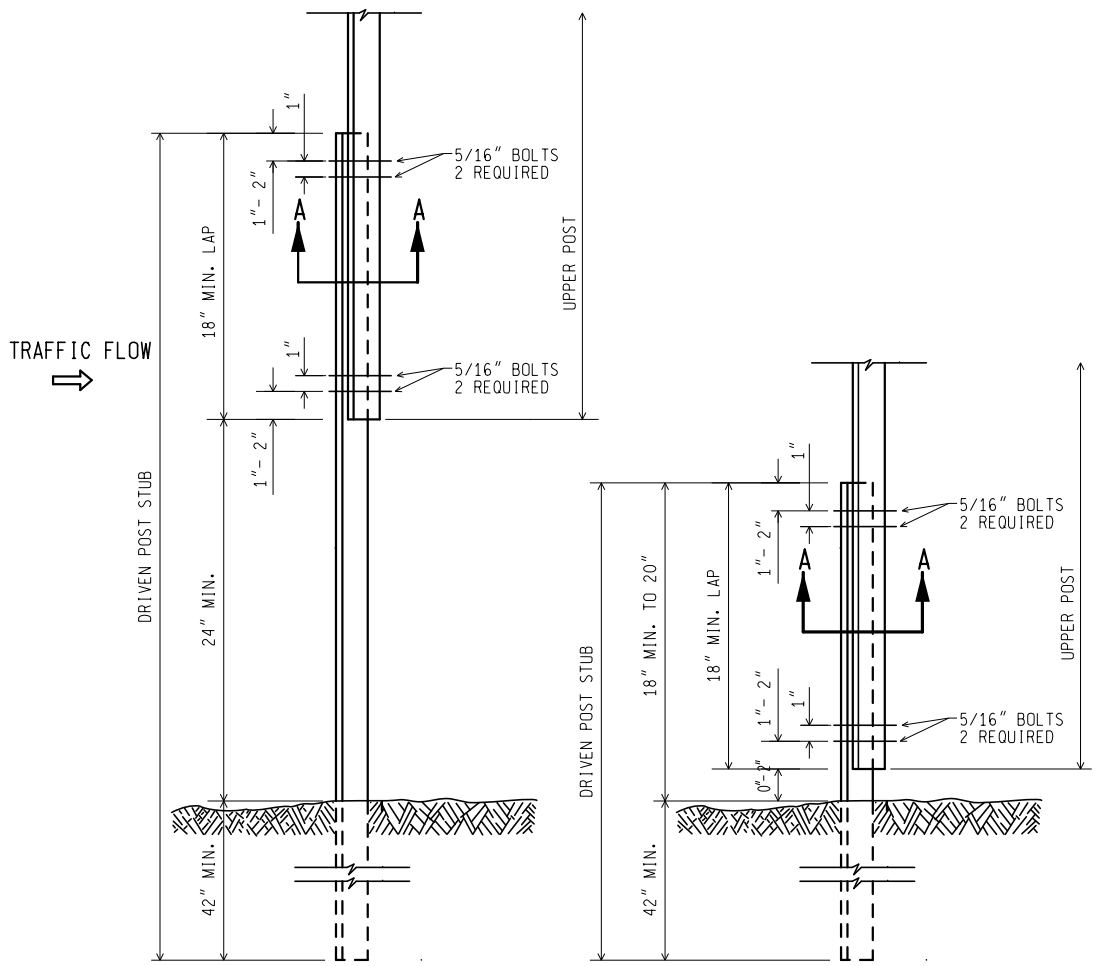

3 lb. U - CHANNEL STEEL POST
(WITH SPLICE)

MOUNT SIGN ON OPEN FACE OF
UPPER U - CHANNEL STEEL POST

NOT TO SCALE

MICHIGAN DEPARTMENT OF TRANSPORTATION BUREAU OF FIELD SERVICES SPECIAL DETAIL	F.H.W.A. APPROVAL	7/20/2016 PLAN DATE	WZD-100-A	SHEET 5 OF 11
--	-------------------	------------------------	-----------	------------------

NOTE: THE ORIGINAL SIGNED COPY IS KEPT ON FILE AT THE MICHIGAN DEPARTMENT OF TRANSPORTATION.

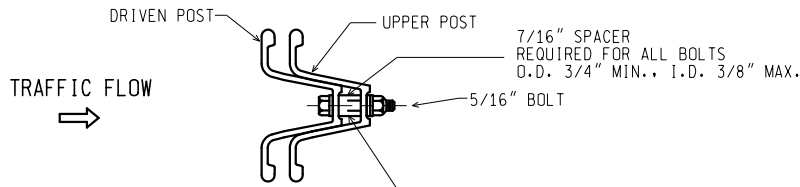

SECTION A-A

7/16" SPACER
 REQUIRED FOR ALL BOLTS
 O.D. 3/4" MIN., I.D. 3/8" MAX.

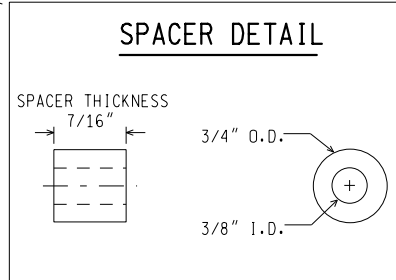

NOTES:

1. THE SPACER THICKNESS SHALL BE 1/16" LESS THAN THE GAP BETWEEN THE POST WHEN POSITIONED IN THE UNBOLTED CONFIGURATION.
2. THE EXTERIOR BOLT (CLOSEST TO LAP), SPACER, WASHER, AND NUT SHALL BE INSTALLED IN A PREPUNCHED HOLE 1" TO 2" FROM THE END OF THE LAP.
3. THE INTERIOR BOLT (FARTHEST FROM LAP), SPACER, WASHER, AND NUT SHALL BE INSTALLED IN THE NEXT PREPUNCHED HOLE.
4. THE DRIVEN POST SHALL ALWAYS BE MOUNTED IN FRONT OF THE UPPER POST WITH RESPECT TO THE ADJACENT ONCOMING TRAFFIC, REGARDLESS OF THE DIRECTION THE SIGN IS FACING.
5. THE SPLICE LAP SHALL BE FASTENED BY FOUR-5/16" DIA. GALVANIZED A449 BOLTS (SAE J429 GRADE 5) OR GALVANIZED A325 BOLTS.

3 lb. U - CHANNEL STEEL POST
 (WITH SPLICE)

NOT TO SCALE

MICHIGAN DEPARTMENT OF TRANSPORTATION BUREAU OF FIELD SERVICES SPECIAL DETAIL	F.H.W.A. APPROVAL	7/20/2016 PLAN DATE	WZD-100-A	SHEET 6 OF 11
--	-------------------	------------------------	-----------	------------------

NOTE: THE ORIGINAL SIGNED COPY IS KEPT ON FILE AT THE MICHIGAN DEPARTMENT OF TRANSPORTATION.

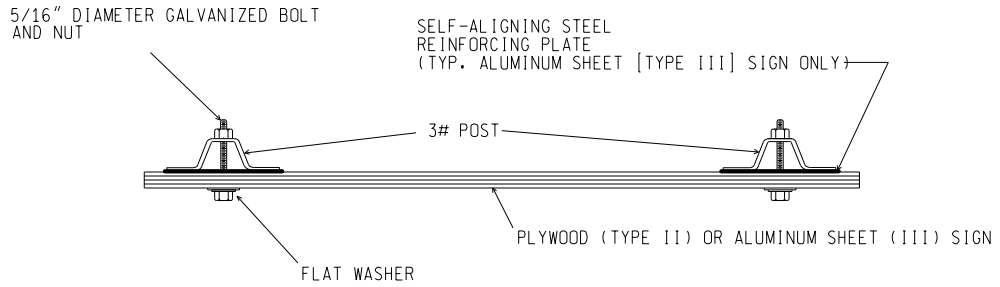

SIGN TO 3 lb. POST CONNECTION

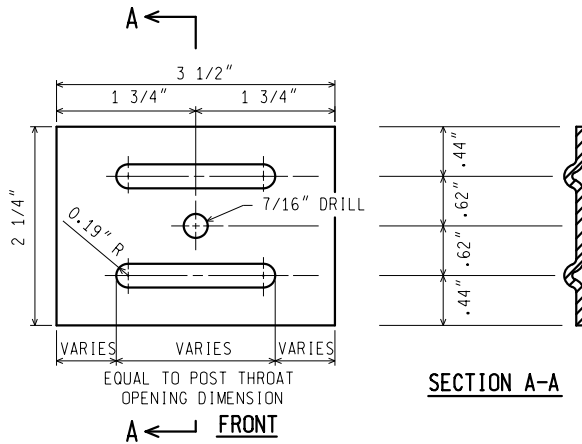

NOTES: (FOR STEEL SIGN REINF' PLATE)

1. MATERIAL: 12 GAUGE CARBON STEEL.
2. TOLERANCE ON ALL DIMENSIONS $\pm 0.0625"$
3. FINISH-AFTER STAMPING AND PUNCHING, GALVANIZE ACCORDING TO CURRENT SPECIFICATIONS FOR ZINC (HOT GALVANIZE) COATINGS ON PRODUCTS FABRICATED FROM PLATES OR STRIPS

STEEL SIGN REINFORCING PLATE
REQUIRED FOR TYPE III SIGNS ONLY

3 lb. U - CHANNEL STEEL POST SIGN CONNECTION

NOT TO SCALE

MICHIGAN DEPARTMENT OF TRANSPORTATION
 BUREAU OF FIELD SERVICES SPECIAL DETAIL

F.H.W.A. APPROVAL

7/20/2016
 PLAN DATE

WZD-100-A

SHEET
 7 OF 11

NOTE: THE ORIGINAL SIGNED COPY IS KEPT ON FILE AT THE MICHIGAN DEPARTMENT OF TRANSPORTATION.

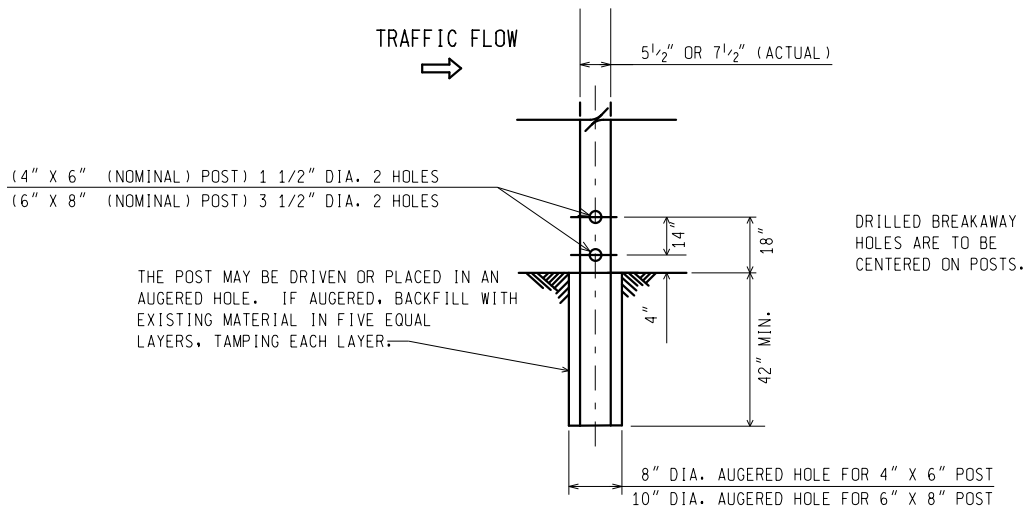

WOOD POST BREAKAWAY HOLES/
DIRECT EMBEDMENT DETAILS

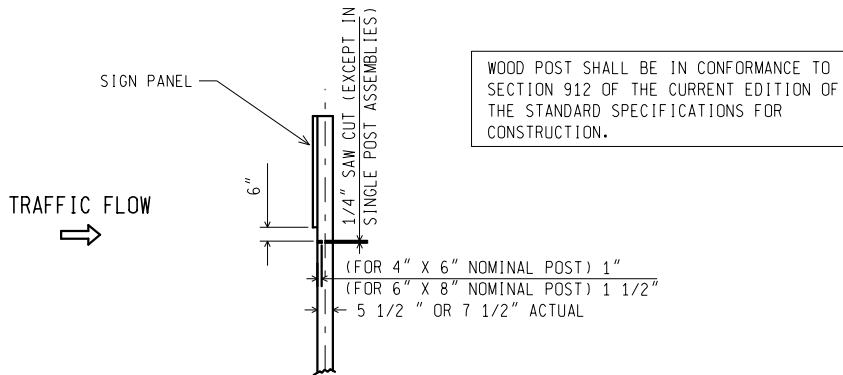

SAW CUT DETAIL
(MULTIPLE POST INSTALLATIONS)

WOOD POST DETAILS

NOT TO SCALE

MICHIGAN DEPARTMENT OF TRANSPORTATION
BUREAU OF FIELD SERVICES SPECIAL DETAIL

F.H.W.A. APPROVAL

7/20/2016
PLAN DATE

WZD-100-A

SHEET
8 OF 11

NOTE: THE ORIGINAL SIGNED COPY IS KEPT ON FILE AT THE MICHIGAN DEPARTMENT OF TRANSPORTATION.

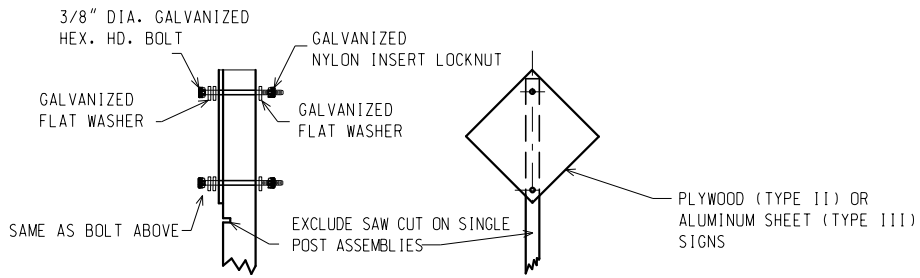

TYPE II AND TYPE III SIGNS

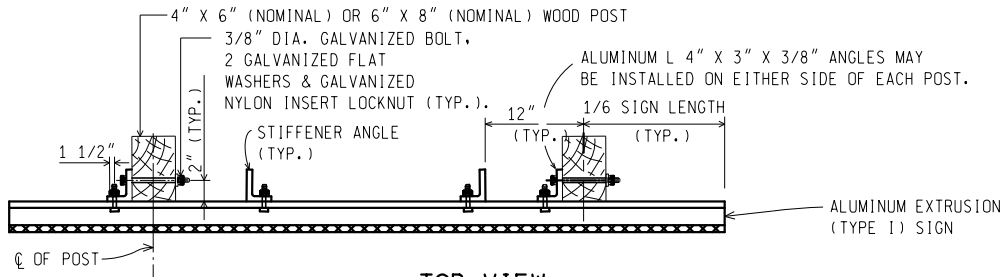

**TOP VIEW
 TYPE I SIGN**

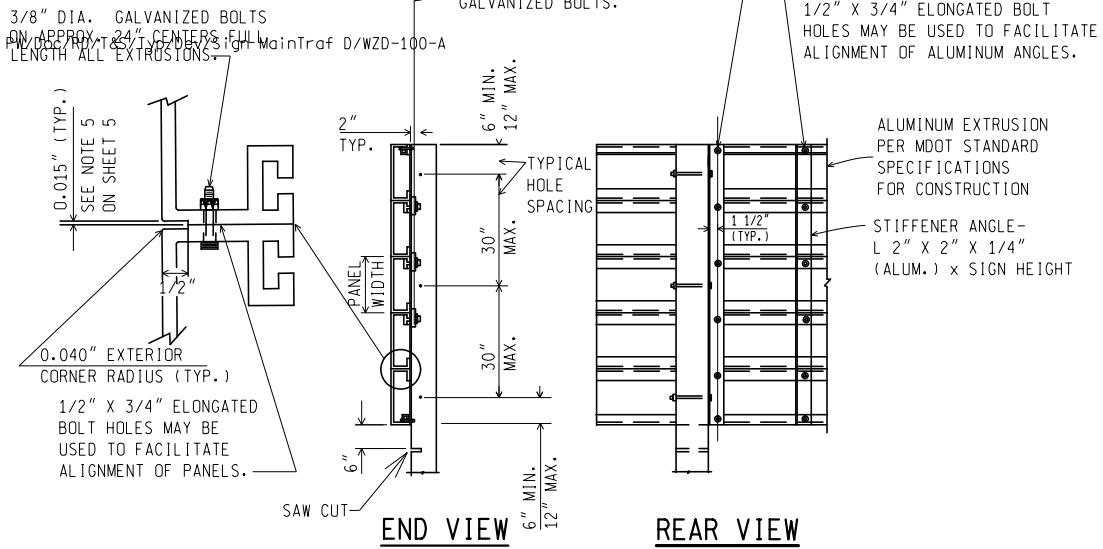

TYPE I SIGN - ERECTION DETAILS

WOOD POST CONNECTIONS

NOT TO SCALE

MICHIGAN DEPARTMENT OF TRANSPORTATION
 BUREAU OF FIELD SERVICES SPECIAL DETAIL

F.H.W.A. APPROVAL

7/20/2016
 PLAN DATE

WZD-100-A

SHEET
 9 OF 11

NOTE: THE ORIGINAL SIGNED COPY IS KEPT ON FILE AT THE MICHIGAN DEPARTMENT OF TRANSPORTATION.

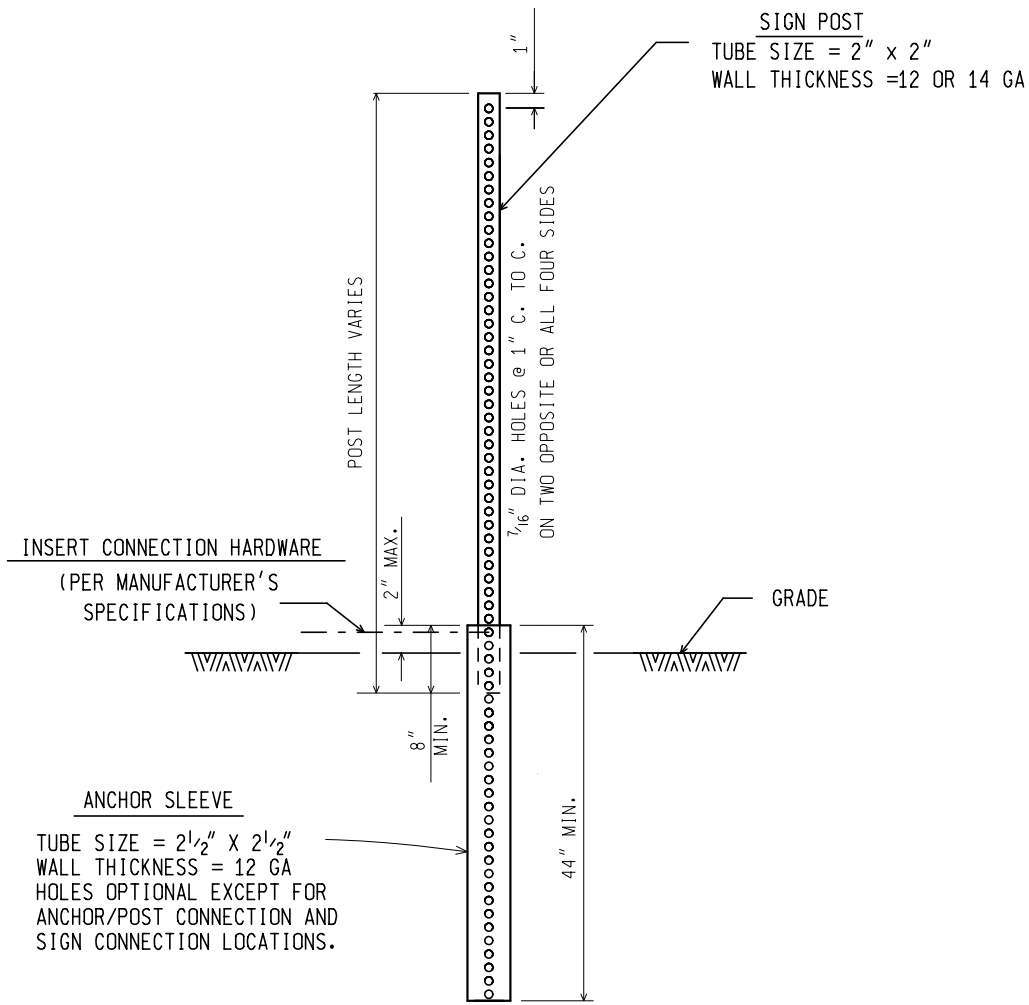

SQUARE TUBULAR STEEL POST

NOT TO SCALE

MICHIGAN DEPARTMENT OF TRANSPORTATION BUREAU OF FIELD SERVICES SPECIAL DETAIL	F.H.W.A. APPROVAL	7/20/2016 PLAN DATE	WZD-100-A	SHEET 10 OF 11
--	-------------------	------------------------	-----------	-------------------

NOTE: THE ORIGINAL SIGNED COPY IS KEPT ON FILE AT THE MICHIGAN DEPARTMENT OF TRANSPORTATION.

GENERAL NOTES:

1. A MAXIMUM OF TWO POSTS WITHIN A 7 FOOT PATH IS PERMITTED.
2. ALL SIGN POSTS SHALL COMPLY WITH NCHRP 350.
3. ALL POSTS SHALL BE EMBEDDED A MINIMUM OF 42".
4. BRACING OF POST IS NOT PERMITTED.
5. SIGN SHALL BE LEVEL, AND UPRIGHT FOR THE DURATION OF INSTALLATION.
6. ERECT POSTS SO THE SIGN FACE AND SUPPORTS DO NOT VARY FROM PLUMB BY MORE THAN 3/16" IN 3'. PROVIDE A CENTER-TO-CENTER DISTANCE BETWEEN POSTS WITHIN 2 PERCENT OF PLAN DISTANCE.
7. NO MORE THAN ONE SPLICE PER POST, AS SHOWN, WILL BE PERMITTED.
8. POST TYPES SHALL NOT BE MIXED WITHIN A SIGN SUPPORT INSTALLATION.
9. NO VERTICAL JOINTS ARE PERMITTED IN SIGN. NO HORIZONTAL JOINTS THROUGH SIGN LEGEND OR SYMBOLS ARE PERMITTED IN SIGN
10. REMOVE SIGN POSTS AND/OR POST STUBS IN THEIR ENTIRETY WHEN NO LONGER REQUIRED.
11. ALL LABOR, MATERIALS, AND EQUIPMENT, INCLUDING TEMPORARY SUPPORTS REQUIRED TO INSTALL, MAINTAIN, RELOCATE, AND/OR REMOVE THE TEMPORARY SIGN, INCLUDING SUPPORTS, ARE CONSIDERED TO BE INCLUDED IN THE COST OF THE TEMPORARY SIGN.
12. SAW CUTS IN WOOD POSTS ARE TO BE PARALLEL TO THE BOTTOM OF THE SIGN.
13. POSTS SHALL NOT EXTEND MORE THAN 4" ABOVE TOP OF SIGN.
14. TEMPORARY WOOD SUPPORTS DO NOT REQUIRE PRESERVATIVE TREATMENT.

NOT TO SCALE

MICHIGAN DEPARTMENT OF TRANSPORTATION BUREAU OF FIELD SERVICES SPECIAL DETAIL	F.H.W.A. APPROVAL	7/20/2016 PLAN DATE	WZD-100-A	SHEET 11 OF 11
--	-------------------	------------------------	-----------	-------------------

NOTE: THE ORIGINAL SIGNED COPY IS KEPT ON FILE AT THE MICHIGAN DEPARTMENT OF TRANSPORTATION.

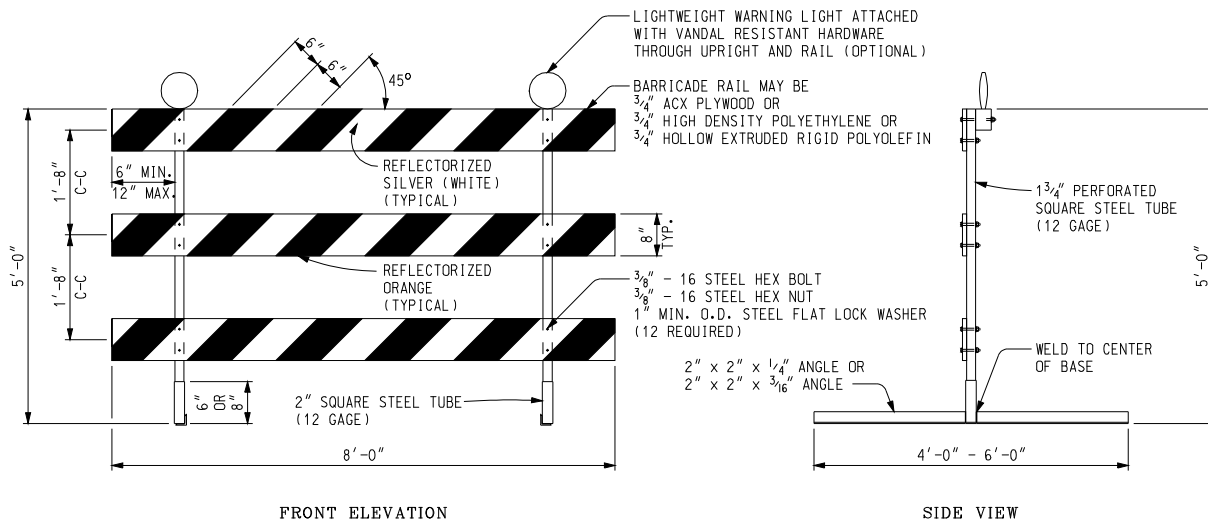

PERFORATED SQUARE STEEL TUBE OPTION

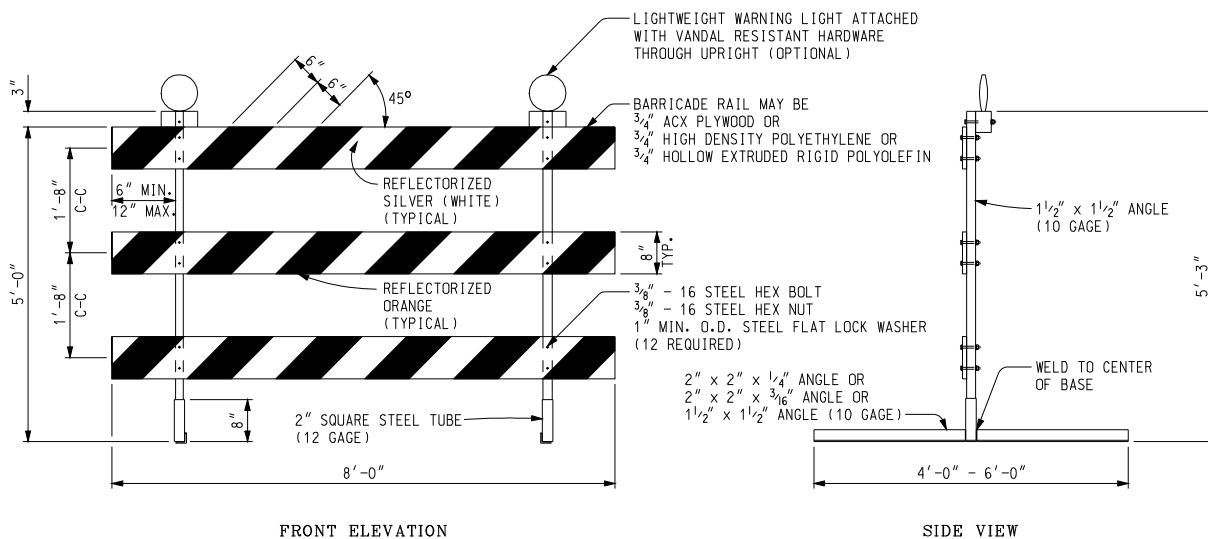

ANGLE IRON OPTION

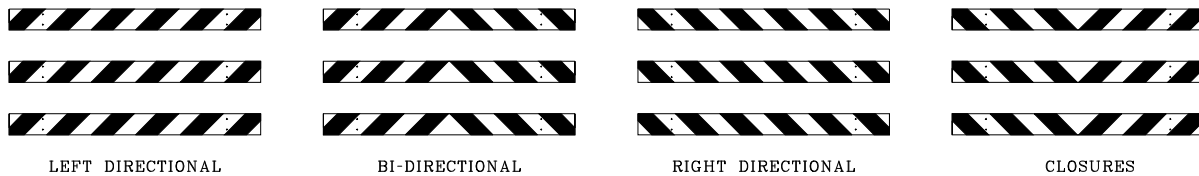

BARRICADE RAIL SHEETING OPTIONS
TYPE III BARRICADES

Other Type III Barricades meeting current NCHRP crash worthy criteria can be found on the FHWA Safety website at

http://safety.fhwa.dot.gov/roadway_dept/road_hardware/wzd.htm

NOT TO SCALE

File: T&S/Typ/Signs/WorkZones/wzd 125 d

Rev. 09/22/09 PJ



PREPARED BY
TRAFFIC AND SAFETY

DRAWN BY: ECH

CHECKED BY: MWB

ENGINEER OF DELIVERY

ENGINEER OF DEVELOPMENT

(SPECIAL DETAIL)

FHWA APPROVAL DATE

MICHIGAN DEPARTMENT OF TRANSPORTATION
BUREAU OF HIGHWAYS DELIVERY STANDARD PLAN FOR

Temporary
Traffic Control Devices

9/22/09
PLAN DATE

WZD-125-E

SHEET
1 of 3

NOTE: THE ORIGINAL SIGNED COPY IS KEPT ON FILE AT THE MICHIGAN DEPARTMENT OF TRANSPORTATION.

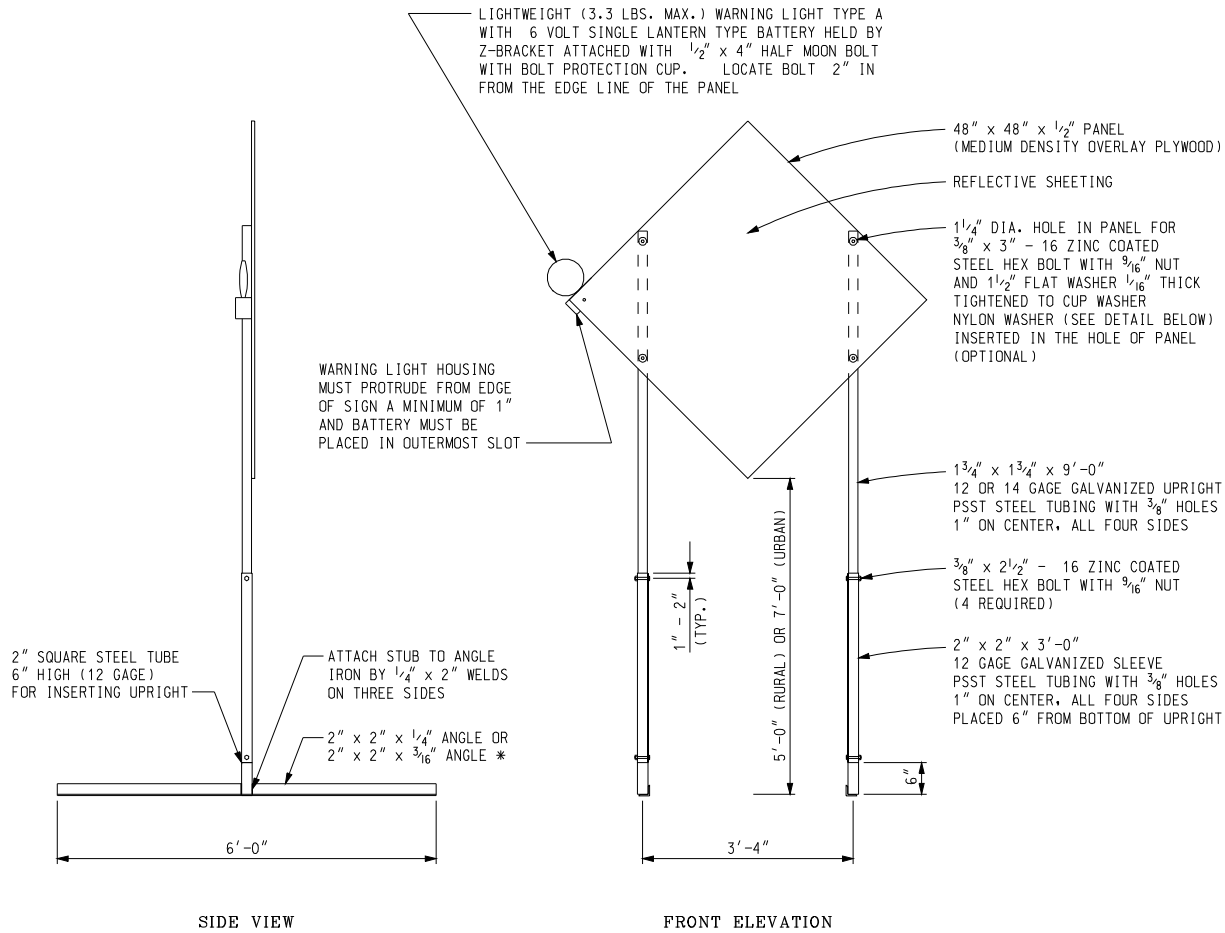

TEMPORARY SIGN SUPPORT

(WARNING LIGHT PLACED ON SIDE CLOSEST TO TRAFFIC)

* SIGN STAND IS BALLASTED WITH FOUR OR MORE 35 LB SANDBAGS. A MINIMUM OF ONE ON EACH END.
 UPRIGHTS SHALL NOT EXTEND ABOVE THE SIGN PANEL.

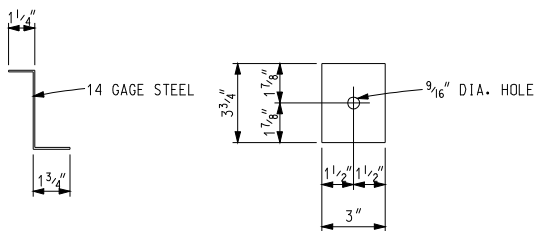

Z-BRACKET DETAIL

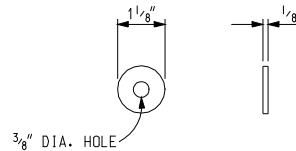

OPTIONAL NYLON WASHER

Other temporary sign supports meeting current NCHRP crash worthy criteria can be found on the FHWA Safety website at http://safety.fhwa.dot.gov/roadway_dept/road_hardware/wzd.htm

NOT TO SCALE

MICHIGAN DEPARTMENT OF TRANSPORTATION
 BUREAU OF HIGHWAYS DELIVERY STANDARD PLAN

(SPECIAL DETAIL)
 FHWA APPROVAL DATE

9/22/09
 PLAN DATE

WZD-125-E

SHEET
 2 of 3

NOTE: THE ORIGINAL SIGNED COPY IS KEPT ON FILE AT THE MICHIGAN DEPARTMENT OF TRANSPORTATION.

- PLASTIC DRUM
- ▲▲▲ PROPOSED TYPE III BARRICADE
- △△△ EXISTING TYPE III BARRICADE

SYMBOLS TO BE USED ON PLANS

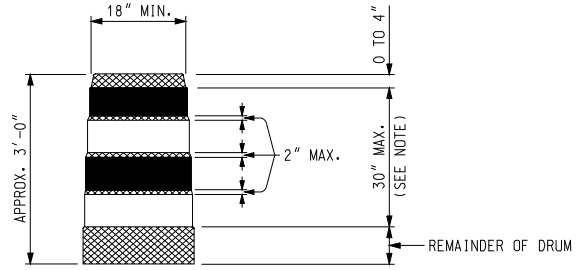

- REFLECTORIZED ORANGE
- REFLECTORIZED WHITE
- ▨ NON REFLECTORIZED ORANGE

NOTE:
 DRUMS SHALL HAVE AT LEAST 4 HORIZONTAL REFLECTORIZED STRIPES (2 ORANGE AND 2 WHITE) OF 6" UNIFORM WIDTH, ALTERNATING IN COLOR WITH THE TOPMOST REFLECTORIZED STRIPE BEING ORANGE. NON REFLECTORIZED SPACES BETWEEN THE HORIZONTAL REFLECTORIZED ORANGE AND WHITE STRIPES SHALL BE ORANGE IN COLOR AND EQUAL IN WIDTH.

PLASTIC DRUM

NOTES:

2" PERFORATED SQUARE STEEL TUBES MAY BE USED TO FABRICATE THE HORIZONTAL BASE OF THE TYPE III BARRICADE.

WARNING LIGHTS SHALL BE PLACED ACCORDING TO THE CURRENT STANDARD SPECIFICATIONS FOR CONSTRUCTION AND ALL OTHER PROVISIONS IN THE CONTRACT WHEN THEY ARE USED ON TYPE III BARRICADES.

SEE ROAD STANDARD PLANS R-113-SERIES FOR TEMPORARY CROSSOVERS FOR DIVIDED ROADWAY, AND R-126-SERIES FOR TYPICAL LOCATION AND SPACING OF PLASTIC DRUMS FOR PLACEMENT OF TEMPORARY CONCRETE BARRIER.

SIGNS, BARRICADES, AND PLASTIC DRUMS SHALL BE FACED WITH PRESSURE-SENSITIVE REFLECTIVE SHEETING ACCORDING TO THE CURRENT STANDARD SPECIFICATIONS FOR CONSTRUCTION.

SANDBAGS SHALL BE USED WHEN SUPPLEMENTAL WEIGHTS ARE REQUIRED TO ACHIEVE STABILITY OF THE BARRICADE. THE SANDBAGS SHALL BE PLACED SO THEY WILL NOT COVER OR OBSTRUCT ANY REFLECTIVE PORTION OF THE TRAFFIC CONTROL DEVICE.

NOT TO SCALE

MICHIGAN DEPARTMENT OF TRANSPORTATION BUREAU OF HIGHWAYS DELIVERY STANDARD PLAN	(SPECIAL DETAIL) FHWA APPROVAL DATE	9/22/09	WZD-125-E	SHEET 3 of 3
File: T&S/Typ/Signs/WorkZones/wzd 125 d	Rev. 09/22/09 PJ	PLAN DATE		

NOTE: THE ORIGINAL SIGNED COPY IS KEPT ON FILE AT THE MICHIGAN DEPARTMENT OF TRANSPORTATION.

CITY OF OWOSSO
SPECIAL PROVISION
FOR
AGGREGATE BASE, _ INCH, MODIFIED

City of Owosso/RC

1 of 1

Dec, 2018

a. Description. This work shall consist of placing and compacting an aggregate base course on a prepared subbase.

b. Materials. The material shall meet the gradation requirements of the Michigan Department of Transportation (MDOT) 2012 Standard Specifications for Construction, Section 902, for 21AA aggregate, except all material shall be 100% crushed limestone.

c. Construction Methods. The material shall be placed and compacted in accordance with the MDOT 2012 Standard Specifications for Construction, Section 302.03.

d. Measurement and Payment. The completed work, Aggregate Base, _ inch, Modified including all materials, labor, and equipment, as measured will be paid for at the Contract Unit Price for the following Contract Item (Pay Item).

Contract Item (Pay Item)

Pay Unit

Aggregate Base, _ inch, ModifiedSquare Yard

Aggregate Base, _ inch, Modified will be measured in place by the square yard.

The maximum pay width will be as shown on the plans.

**SPECIAL PROVISION
FOR
ASPHALT STABILIZED AGGREGATE BASE COURSE**

CITY OF OWOSSO/RC

1 OF 3

October, 2018

DESCRIPTION

This work will be done in accordance with the requirements of Section 305, 501, 902, and 904 of the Michigan Department of Transportation (MDOT) 2012 Standard Specifications for Construction, except as herein specified.

This work shall be accomplished in place and shall consist of blending crushed material with hot asphalt cement at the specified rate and depth, shaping to specified elevation and slope, and compacting to specified density.

MATERIALS

Materials shall meet the following requirements:

Asphalt Cement PG 52-28	904
Fog Coat SS - 1H	904
Aggregate Base 22A	902

The asphaltic material for stabilizing shall be applied at the rate and temperature (minimum 350° F) as determined by the Engineer, so that the residual bitumen added will be between two (2) and five (5) per cent by weight of the asphaltic material.

EQUIPMENT REQUIREMENTS

1. Compaction Equipment - Rollers. Rollers must meet the requirements as specified under Section 501.03 for rollers, except that combination pneumatic-steel wheel and vibratory rollers will be permitted. A minimum of three (3) rollers in operating condition will be required on the project and shall be of the following types:
 - Minimum of (2) shall be steel drum vibratory type;
 - Minimum of (1) shall be pneumatic - tire type.All rollers are to be approved by the Engineer prior to beginning construction.
2. Stabilizing Equipment - The stabilizing plant shall be a single-pass, multi-drum, self-propelled machine. The mixing chamber shall have a positive depth control to insure a uniform depth of stabilized material and must be capable of loosening the base materials to the depth called for without disturbing the subbase. The stabilizing plant shall add the asphalt in predetermined and accurately metered quantities, while maintaining a constant and fixed rate of forward motion, thoroughly blend the asphalt with the road materials, and spread the mixture uniformly on the roadway.

A spray bar for distribution of the liquid asphalt shall be mounted inside the mixing chamber and shall have nozzles spaced at increments not to exceed six (6) inches and shall operate in such a manner that all asphalt will be uniformly applied throughout the mixing chamber at the time of injection. The asphalt additive system shall consist of a positive displacement pump and shall display the temperature, pressure and flow rate to accurately check the rate of application of the asphalt at any time. Note - Full width processing is required to eliminate longitudinal joints in the stabilizing material necessitating the use of two (2) or more stabilizing machines; depending on the width of road to be processed. The system for distributing the asphalt material shall be adjustable for the rate of asphalt application and shall measure accurately the amount of asphalt material being applied. A foot per minute meter and a gallon per minute meter shall be in clear view of the operator and both shall be controlled by the operator from the operator's station.

CONSTRUCTION METHODS

1. Mixing with Asphalt Materials - Prior to adding the asphaltic material, the moisture content of the crushed material shall be adjusted by aerating or by adding water. The asphaltic material shall be added only to that material which can be completely mixed and compacted in one day. The asphaltic material shall be added through the mixer at the rate and within the temperature range directed by the Engineer. The temperature shall be kept below the flash point of the asphalt cement but shall not fall below 350° F.
2. Shaping, Rolling and Compacting - Shaping and compacting shall be done while the asphalt material is in a workable state. The final shaping and compaction shall be accomplished as soon as possible after addition of the asphaltic material. The mixed material shall be so shaped that when compacted it shall be in a reasonably close conformity with lines, grades, and cross-sections shown on the plans or as directed by the Engineer. Stabilized material trimmed from the grade shall be used adjacent to the shoulder to complete the cross section as shown on the plans. Material in excess of the quantity required to complete the cross section shall become the property of the Contractor.

Initial rolling shall be done with one or more pneumatic-tired rollers. The aggregate-asphalt mixture shall be compacted to not less than 98 percent of the unit weight obtained by the Michigan Modified T 180 Test as described in the Density Control Handbook. Such test shall be made on the aggregate-asphalt mixture at the filled moisture content existing during the compacting operation. Required density shall be maintained until the material has been surfaced. Density testing requirements are hereby waived for this project, but may be used, as directed by the Engineer, to assure density is being maintained. After final

rolling, the Engineer will test the surface using a 10-foot straightedge at selected locations. The variation of the surface from the testing edge of the straightedge between any two contacts with the surface shall at no point exceed $\pm\frac{3}{8}$ inch.

5. Curing - The base may be opened to traffic for a period of time to be determined by the Engineer prior to placing of the surface. Any areas which show evidence of cracking or instability will be investigated and corrected within 48 hours, before any work proceeds. If the stabilized asphalt aggregate pavement is to be left unsurfaced for more than seven (7) days, a fog coat of SS-1H shall be applied at the rate of 0.20 to 0.30 gallons per square yard, at the Contractor's expense.
6. Weather Limitations - Asphaltic material shall not be applied to the grade or to the aggregate when rain is threatening or when the air temperature is lower than 50° F.

The Stabilization work shall be performed in the Lower Peninsula during the period May 15 to October 15, and in the Upper Peninsula during the period June 1 to October 1, unless otherwise authorized by the Engineer.

MEASUREMENT AND PAYMENT

The completed work as measured for asphaltic stabilized aggregate base course will be paid for at the contract unit prices for the following contract items (Pay Items).

<u>Pay Item</u>	<u>Pay Unit</u>
Asphalt Cement Stabilized Base Course, 4 Inch	Square Yard
Asphalt Cement Binder	Gallon

Payment for Asphalt Cement Stabilized Base Course, 4 Inch includes the furnishing, hauling, placing, mixing of the asphalt cement into the crushed base material, shaping, and compacting of the mixture. This item will be measured by completed width and length required in the plans to a maximum depth of four (4) inches.

Payment for Asphalt Cement Binder shall be paid for by the gallon applied to the base course.

Payment for Asphalt Emulsion Fog coat SS-1H will not be paid for separately but will be included as part of the work of Asphalt Cement Stabilized Base Course.

Any aerating or adding water necessary to achieve proper moisture will not be paid for separately but will be included as part of the work of Asphalt Cement Stabilized Base Course.

**SPECIAL PROVISION
FOR
DRAINAGE STRUCTURE COVER EJ _____**

City of Owosso

1 OF 1

Dec, 2018

General Description

Drainage Structure Cover EJ _____, shall consist of materials and work meeting requirements of Section 403 of the MDOT 2012 Standard Specifications for Construction, and as modified herein.

Cover Description

All covers will be manufactured and supplied by East Jordan Iron Works. Cover types shall match with the pay item cover number.

Measurement and Payment

The completed work as measured for Drainage Structure Cover EJ ____ will be paid for at the Contract Unit Price for the following Contract Item (Pay Item):

Contract Item (Pay Item)	Pay Unit
Drainage Structure Cover EJ 1030	Each
Drainage Structure Cover EJ 1060	Each
Drainage Structure Cover EJ 1060 w/ Type M1 Flat Grate	Each
Drainage Structure Cover EJ 1060 w/ Type N Oval Grate	Each
Drainage Structure Cover EJ 1020 w/ Solid Gasket Sealed Cover	Each
Drainage Structure Cover EJ 7000	Each

Drainage Structure Cover EJ ____ will be measured in place by count of Each; and will be paid for at the contract unit price per Each, which price shall be payment in full for all labor, material, and equipment needed to accomplish this work.

**SPECIAL PROVISION
FOR
HMA BASE CRUSHING AND SHAPING, MODIFIED**

CITY OF OWOSSO/RC

1 OF 1

October, 2018

DESCRIPTION:

All work shall consist of crushing and shaping the existing pavement section and gravel base to the depth and width as shown on the plans, or as directed by the Engineer, in accordance with Sections 305 and 501 of the Michigan Department of Transportation (MDOT) 2012 Standard Specifications for Construction and as modified herein.

CONSTRUCTION:

Crush and shape HMA and gravel base at a depth of 6 inches. Use a water sprinkling system as approved by the Engineer. After crushing, 100 percent (100%) of the crushed material shall have a maximum particle size of 1-½ inches (1.5"). Particles exceeding 1-½ inches shall be removed by the Contractor at the Contractors expense. The crushed material shall be initially shaped immediately after the crushing operation to established grade and cross section within a tolerance of ¾ inches and be opened to local traffic at end of same workday. Sufficient material shall be graded along edges (wind rowed) for final grading and blending shoulder after HMA placement. The crushed surface shall be left to cure in place for a period of time not exceeding three calendar days.

Rolling equipment shall be furnished in accordance with Section 501.03, except that combination of pneumatic tired (1 minimum) and steel vibratory (2 minimum) rollers will be used to properly compact the crushed material to achieve density requirements of Section 305.

MEASUREMENT AND PAYMENT:

The completed work as measured for the following Pay Items will be paid for at the Contract Unit Price for the following Contract Item (Pay Item):

Contract Item (Pay Item)	Pay Unit
HMA Base Crushing and Shaping, Modified	Square Yard

HMA Base Crushing and Shaping, Modified will be measured in area by square yard; and will be paid for at the contract unit price per square yard, which price shall be payment in full for all labor, material, and equipment needed to accomplish this work. Shaping includes initial, intermediate, and final shaping of the prepared crushed material.

**SPECIAL PROVISION
FOR
SAWCUTTING**

City of Owosso/RC

1 OF 1

Jan, 2019

DESCRIPTION

This work shall be accomplished in accordance with Section 501 of Michigan Department of Transportation 2012 Standard Specifications for Construction except as modified herein.

METHOD OF CONSTRUCTION

This item shall be for sawing HMA pavement, driveway approaches, sidewalks, and curb and gutter; wherever a joint of any does not exist; as shown on the plans and/or as directed by the Engineer. Sawcutting depths shall be full depth.

MEASUREMENT AND PAYMENT

The completed work as measured for Sawcutting will be paid for at the contract unit price for the following contact item (Pay Item).

<u>Pay Item</u>	<u>Pay Unit</u>
Sawcutting	Linear Foot

Sawcutting will be measured by length in feet; and will be paid for at the contract unit price per foot, which price shall be payment in full for all labor, material, and equipment needed to accomplish this work.

**SPECIAL PROVISION
FOR
TRENCHING, MODIFIED**

CITY OF OWOSSO/RC

1 OF 1

October, 2018

DESCRIPTION:

This work item shall consist of trenching either one or both sides of the existing pavement section so as to accommodate the widening for proposed pavement, to the depth as shown on the plans, or as directed by the Engineer. All work shall be done in accordance with Section 307 of the Michigan Department of Transportation (MDOT) 2012 Specifications for Construction and as modified herein.

METHOD OF CONSTRUCTION

The Contractor shall trench along the existing pavement edge at varying widths and varying depths as shown on the plans. The trench shall be excavated to the proposed width and depth. Any disturbed underlying soil shall be properly compacted, as directed by the Engineer. Some select excavated material may be leveled as embankment on-site, adjacent to the proposed pavement edge, as directed by the Engineer. Excess excavated material shall become responsibility of the Contractor for proper disposal.

METHOD OF MEASUREMENT AND PAYMENT

The completed work as measured for Trenching, Modified will be paid for at the Contract Unit Price for the following Contract Item (Pay Item).

CONTRACT ITEM (Pay Item)

Pay Unit

Trenching, Modified

Station

Trenching, Modified will be measured in length by stations; separately along each side of existing pavement; and will be paid for at the Contract unit price per station, which price shall be payment in full for all labor, material, and equipment needed to accomplish this work. Disposal of all excess material is included as part of the pay item Trenching, Modified.

**SPECIAL ROVISION
FOR
TURF ESTABLISHMENT, PERFORMANCE**

City of Owosso/RC

1 of 5

Jan, 2019

a. Description. For the work identified in this special provision paid for by the pay item Turf Establishment, Performance only, delete section 816 of the Standard Specifications for Construction and replace it with this special provision. The Contractor is responsible for the performance and quality of turf growth in the areas indicated on the plans and as identified by the Engineer. Comply with all local, state and federal laws when completing this work.

Establish a durable, permanent, weed-free, mature, perennial turf. The work consists of fundamental turf work, including but not limited to top soiling, seeding, mulching, erosion control, maintenance, watering and repair of turf as described herein during the life of the contract and during the life of any supplemental performance bond which may ensue.

Choose and implement proven turf establishment industry practices; provide all necessary labor and equipment; select and provide all turf establishment materials; and control erosion and any subsequent sedimentation at all times.

Perform a site analysis, interpret the results and implement a turf establishment program to ensure compliance with this specification. The site analysis must take into consideration topsoil needs, fertilizer and pH requirements, seed mix, existing and future soil moisture levels, slopes and grades, required erosion control items and devices, maintenance requirements, local highway snow removal and deicing practices, and any other characteristics that influence and affect turf establishment.

Subsection 107.11 of the Standard Specifications for Construction is revised relative to the Contractor's responsibility for the repair of turf establishment work as follows. The Contractor is responsible, at no additional cost to the contract, for the repair of turf establishment work occasioned by storm events up to 3 inches of rain in a 24 hour period as documented by local meteorological data submitted to the Engineer for review and approval. All other portions of subsection 107.11 remain unchanged.

1. Contractor Turf Establishment Experience Requirements. Ensure weed control is done by a commercial herbicide applicator, licensed by the State of Michigan and certified by the Michigan Department of Agriculture (MDA) in the appropriate category to apply herbicides. Use application procedures and materials according to federal, state and local regulations. Use of restricted use chemicals is prohibited. Provide appropriate documentation and secure approval from the Engineer before application of herbicides.

At least 10 work days prior to start of turf establishment, provide documentation to the Engineer, from the Contractor performing the turf establishment work, that they meet one or both of the following requirements.

A. At least one person employed by the Contractor performing the turf establishment work and assigned to the job site has a degree or certificate in Turf

Management, Horticulture or related field.

B. At least one person employed by the Contractor performing the turf establishment work and assigned to the job site has at least 5 years of experience in roadside turf establishment.

b. Materials. Provide topsoil, seed, mulch, pesticide, herbicide, mulch blankets and any other unique erosion control materials as necessary to fulfill this specification, as detailed on the plans. Use additional materials, as necessary, to meet the standards set forth for turf establishment in this special provision. The use of sod on the project requires the prior approval of the Engineer and if approved, may be used at limited site locations only.

Selection of all materials is the responsibility of the Contractor with the following minimum conditions.

1. Soil. Provide furnished or salvaged topsoil, which may be blended compost, that will support vigorous growth. Ensure topsoil is humus bearing and placed at least 4 inches deep. Ensure it is free of stones larger than 1/2 inch (2 inches on freeway projects) in diameter and other debris. Trim and grade the finished slope in accordance with subsection 205.03.N of the Standard Specifications for Construction.

2. Seed. Use a seeding mixture that is composed of four or more species of perennial grass. Use only species and their cultivars or varieties which are guaranteed hardy for Michigan.

Recommended species of perennial grasses include: Kentucky Bluegrass, Perennial Ryegrass, Hard Fescue, Creeping Red Fescue, Chewings Fescue, Turf-type Tall Fescue, Buffalo grass, and Alkaligrass-Fults Puccinellia distans. Select cultivars or varieties of grasses that are disease and insect resistant and of good color. Ensure that no one species in the mix is less than 5 percent, or more than 25 percent, of the mixture by weight. Do not select grass species considered noxious or objectionable, such as Quack Grass, Smooth Brome, Orchard Grass, Reed Canary Grass and others.

A. Ensure the seed is legally saleable in Michigan. Ensure the seed product does not contain more than 10 percent inert materials. Ensure the seed source is an MDOT approved certified vender.

B. Adapt the species and varieties of seed to the site conditions, to the site use, and to the soils, moisture and local climate. Site use may include, but is not limited to, detention pond, wildlife habitat, playground, wetlands, forested wetland, rural roadside, urban roadside and highly maintained front yard.

C. Ensure at least two of the species in the mixture proposed to be planted within 15 feet behind the curb or the shoulder are salt tolerant.

3. Mulch. Mulch seeded areas with the appropriate materials for the site conditions to promote germination and growth of seed and to mitigate soil erosion and sedimentation.

4. Herbicides. Comply with all federal, state and local laws. As part of the MDA weed control application, the Contractor is required to make proper notifications and/or postings as per label and MDA requirements for all locations that will be sprayed. Notify the Engineer at least 48 hours prior to any applications being made. Furnish and apply herbicide(s) as

needed. It is the Contractor's responsibility to select the herbicide(s) and the rate at which it is used. Obtain the Engineer's approval of work methods and herbicide(s) selected prior to the application of the herbicide(s). Complete a spray log and submit to the Engineer each day an application is made.

Do not draw water from any waterway (i.e. river, ditch, creek, lake etc.) located on state, county or municipal right-of-way, for mixing with herbicides.

5. Fertilizers. Furnish and apply fertilizer(s) as needed. It is the Contractor's responsibility to select the fertilizer(s) and the rate at which it is used. Phosphorus is allowed for use only at the time of planting and when required by soil conditions. Obtain the Engineer's approval of work methods and fertilizer(s) prior to the application of the fertilizer(s).

6. Water. Furnish and apply water from an approved source at a rate to promote healthy growth.

c. Construction. The Contractor is responsible for all work and all construction methods used in completing this work. Implementation of any part of the standard specifications or standard plans by the Contractor does not relieve the Contractor of responsibility for acceptability of the construction methods or for the quality of the work.

1. Inspection of the Work. The Contractor is responsible for all inspection of turf establishment work.

Use a Contractor's Daily Report, approved by the Engineer, to report inspections made and to document turf establishment work performed on this project. Complete and submit a Contractor's Daily Report to the Engineer when any work performed under this special provision is in progress.

Include all necessary materials documentation including tests slips, certifications, etc. with the associated Contractor's Daily Report.

The Engineer will determine the acceptability of the Contractor's Daily Report in terms of their completeness and accuracy. The Engineer reserves the right to verify all submitted measurements and computations. Failure by the Contractor to submit acceptable and timely reports to the Engineer may result in withholding of progress pay estimates on turf-related items until such time as reports are submitted and deemed acceptable.

The Engineer reserves the right to inspect the project for any reason in accordance with subsection 104.01 of the Standard Specifications for Construction, including the fulfillment of other inspection requirements such as Soil Erosion and Sedimentation Control, NPDES, etc. Inspections made by the Engineer do not relieve the Contractor of the responsibility for inspections required by this special provision or the Contractor's responsibilities for erosion control and turf establishment.

2. Erosion Control. Control erosion at all times according to section 208 of the Standard Specifications for Construction. Control of soil erosion is the responsibility of the Contractor. However, sedimentation controls must be placed as indicated on the plans or as directed by the Engineer. Continuously monitor the site for needed erosion repair from any cause as addressed in the contract. Return all eroded areas to original grade as detailed in the contract.

Take immediate corrective action if sedimentation occurs in drainage structures or any watercourse or water containment area and stabilize all disturbed areas contributing to this sedimentation within 24 hours after the erosion occurrence. Remove sediment deposited as a result of the Contractor's inability to control the soil erosion at the Contractor's expense.

Reimburse the Department for any costs levied against the Department, such as fines, environmental costs, costs for remedies required, or any other costs as a result of the Contractor's failure to comply with this special provision and with federal, state and local laws.

3. Erosion Repair. The Contractor is responsible for all repairs and liable for all consequences (legal, monetary or other) associated with erosion or sedimentation damage to finished or unfinished work.

Report all erosion occurrences and the repairs made by the Contractor to the Engineer in the format and at the frequency required by the Engineer. Repair any erosion, displacement or disturbance to ongoing or completed work by any cause at no additional cost to the contract unless otherwise noted herein.

The Contractor is responsible and liable for all traffic control and safety measures required to repair and protect damaged turf areas. Repair any eroded area that may affect the support of the roadbed or safety of the public within 24 hours of the erosion occurrence.

Place protective devices such as barriers, directional signs/signals, temporary fence, or any other safety measures immediately after any erosion damage occurs that has the potential of endangering the public. In these instances, provide the Engineer with a written summary of the immediate action taken describing the repairs made and the safety measures taken, within 24 hours of the occurrence of the damage.

4. Mowing and Weeding. Maintain turf to a visually appealing level, and not more than 8 inches in height at any time, prior to acceptance. Weeds must be controlled to less than 10 percent of the turf establishment area at all times during construction.

5. Final Acceptance and Supplemental Performance Bond.

A. Final Acceptance Parameters. Ensure before final acceptance of the turf establishment work, all of the following minimum parameters are met throughout all exposed areas of the project designated on the plans or identified by the Engineer as turf establishment areas: there must be no exposed bare soil and the turf must be fully germinated, erosion free, weed free, disease free, dark green in color and in a vigorous growing condition.

The Engineer will notify the Contractor of the dates and times of all acceptance inspections. The Contractor may accompany the Engineer during these inspections. If the Contractor does not agree with the decision made by the Engineer, the Contractor may request an inspection by a mutually agreed upon third party (Michigan State University Extension service or other). A joint inspection, to include the Engineer, the Contractor, and the third party, will be scheduled by the Engineer. Pay all expert fees and expenses charged by the third party.

B. Supplemental Performance Bond. In the event that all contract items of work are

completed, including the placement of all turf establishment items of work, and the final acceptance of the project is delayed because the final acceptance parameters for the turf establishment work have not been fully met; the Contractor may propose to the Engineer the use of a supplemental performance bond.

The bond serves to secure the successful completion of turf establishment work and fulfillment of all final acceptance parameters for the turf establishment work. Ensure the supplemental performance bond, in all respects, is satisfactory and acceptable to the Department and executed by a surety company authorized to do business with the State of Michigan.

Ensure the bond is in an amount equal to 50 percent of the turf establishment work items covered by this special provision. Ensure the bond remains in place for two growing seasons. At the discretion of the Engineer, the bond may be reduced on a prorated basis as portions of the areas designated for turf establishment on the project meet the final acceptance parameters.

Prior to commencement of any work necessary to meet the acceptance parameters during the bonded period, the Contractor must apply for a permit to work within MDOT right-of-way using Form 2205. The permit fee and an individual permit performance bond will not be required. The permit insurance requirements, however, will be required.

d. Measurement and Payment. The completed work, as described, will be measured and paid for at the contract unit price using the following pay item:

Pay Item	Pay Unit
Turf Establishment, Performance.....	Square Yard

Turf Establishment, Performance will include all labor, equipment and materials required or selected by the Contractor to install, maintain, inspect, repair and meet the acceptance parameters for turf establishment specified in this special provision, including preparation, updating and submittal of the Contractor’s Daily Reports.

Repairs made to damaged turf establishment areas as a result of a documented storm by local meteorological data resulting in rainfall amounts of more than 3 inches in a 24 hour period will be paid for as an increase to original quantities in accordance with subsection 109.05 of the Standard Specifications for Construction.

The following schedule of payment applies to work performed according to this special provision. Upon completion of topsoil surfacing stage, 50 percent of the authorized amount for **Turf Establishment, Performance** will be paid to the Contractor. The remaining 50 percent of the authorized amount will be paid upon completion of all other work necessary to comply with this special provision and to meet all final acceptance parameters for **Turf Establishment, Performance** or at such time as the supplemental performance bond is accepted by the Department.

The supplemental performance bond and all costs associated with turf establishment work performed during the duration of the performance bond will not be paid for separately. These costs which may include, but are not limited to, mobilization, traffic control devices, and the required permit insurance are included in the unit price bid for **Turf Establishment, Performance**.

**SPECIAL PROVISION
FOR
VALVE BOX, ADJUST**

City of Owosso/RC

1 OF 1

Dec, 2018

Description

The work of Valve Box, Adjust shall be done in accordance with Section 403 of the MDOT 2012 Standard Specifications for Construction, and as modified herein. This work shall include the proper setting and support of valve boxes within the proposed pavement area.

Method of Construction

This work item shall include adjustment of water valve boxes and covers to final grade in advance of the final course of HMA. The Contractor shall sawcut, remove adjacent pavement, center box over the water valve, set and support cover to the required elevation, and replace pavement at six inch depth with HMA of same type and mix as top course material.

Measurement and Payment

The completed work as measured for Valve Box, Adjust will be paid for at the contract unit price for the following contract pay item (Pay Item):

Contract Item (Pay Item)	Pay Unit
Valve Box, Adjust	Each

Valve Box, Adjust will be measured in in place by the unit Each and will be paid for at the contract unit price per Each, which price shall be payment in full for all labor, material, and equipment needed to accomplish this work.

The unit price for Valve Box, Adjust includes the following:

1. Sawcutting existing pavement.
2. Adjusting and supporting the valve box.
3. Removing and replacing HMA adjacent to the adjusted cover.